



Instruction for Operation and Maintenance



ECO SNL

Single Stage Norm Centrifugal Pumps

yaşamı koru! save life!

Instructions for Installation, Operation and Maintenance

Standart Pompa ve Makina San. Tic. A.Ş.

**All rights reserved. Can not be copied or reproduced for any purpose without permission.
Subject in the manual can be changed without any prior notice.**

**09.2019
Revision 1**

Contents

1. GENERAL	01
1.1 Safety Signs	01
1.2 General Instructions	01
1.3 Safety Instructions	02
1.3.1 CE signs and approvals	02
1.3.2 Explosive atmosphere	03
1.3.3 Labelling	03
1.3.4 Temperature classes and limits	03
1.3.5 Monitoring	04
1.3.6 Constructional requirements	04
1.3.7 Personal qualification and training	04
1.4 Recycling	04
2. GENERAL PUMP DESCRIPTION	05
2.1 Pump Description	05
2.2 Application Areas	05
2.3 Pump Designation	05
2.4 European Commission's Regulation	05
2.5 Pump Nameplate	06
2.6 Technical Information	06
3. UNPACKING, HANDLING and STORAGE	06
3.1 Unpacking	06
3.2 Handling	06
3.2.1 General warnings	06
3.2.2 Lifting operation	07
3.3 Storage	07
4. INSTALLATION ON SITE	08
4.1 Bare Shaft Pump	08
4.2 Preparation for Installation	08
4.3 Installation Site	08
4.4 Installation Of The Piping System	08
4.4.1 General Warning	08
4.4.2 Suction pipe	09
4.4.3 Delivery pipe	09
4.4.4 Auxillary pipe connections and accessories	11
4.5 Minimum Flow	12
4.6 Electrical Connections	12
4.7 Final Controls	13

Contents

5. START UP / SHUT DOWN	14
5.1 Preparation	14
5.1.1 Venting and priming	14
5.1.2 Checking the direction of rotation	14
5.2 Start Up The Pump	14
5.3 Shut Down The Pump	15
5.4 Checks to be Made While The Pump is Running	15
6. DISASSEMBLY AND REASSEMBLY	15
6.1 Disassembling the Pump	15
6.2 Tightening Torques	16
6.3 Assembling the Pump	17
6.3.1 Getting Prepared for Mounting	17
6.3.2 Mounting	17
6.4 Shaft Seal	18
6.4.1 Pump with mechanical seal	18
7. SPARE PART	19
8. FAULTS, CAUSES AND REMEDIES	20
9. EXPECTED NOISE VALUES	21
10. PUMP DIMENSION GROUPS	22
11. SECTIONAL DRAWINGS	23

1. GENERAL

The objective of this manual is to:

- Instruct the users on installation, dismantling, maintenance and repair of the pump, and
- Describe methods of start-up, operation and stop of the pump.

1.1 Safety Signs



General Risk

Signifies safety precautions which if not applied may cause vital.



Electrical Risk

Warnings about the electrical current



Warning

Safety instructions that if not applied may cause damage to the machine or operation.



Explosive atmosphere

Information to prevent explosion in the explosive atmosphere as per EC Directive 94/9/EC (ATEX)

1.2 General Instructions



This manual should be made available at a safety place easily accessible by personnel responsible for safe operation and maintenance of the pump the qualified

- The authorized personnel should be experienced and well - informed about the related standards.
- The instructions given in this manual should be carefully read and applied at any phase of the installation and operating process of the pump.
- The user is responsible to ensure that the inspection and installation are performed by the authorized and qualified personnel, who read this manual thoroughly.
- The pump should never be operated beyond the operating conditions set forth in the purchase order. The reason is that the operating conditions set forth in the purchase order have been taken into consideration in the selection of the pump material and trial of the pump.
- If the pump is required to be operated apart from the conditions set forth in the purchase order, please contact with **STANDART POMPA**. **STANDART POMPA does not assume any responsibility for any damages that may arise from operation of the pump beyond the specified conditions without written consent.**
- If the pump will not be installed at its place immediately after delivery, it should be stored at a clean and dry place where the ambient temperature does not change excessively. If the proper precautions are not taken, excessively low or high temperatures may cause serious damages to the pump.
- **STANDART POMPA does not accept any responsibility under warranty for any repair or replacement performed by the user or any other unauthorized persons.**
- **This manual does not include safety rules applicable at the place of use.**

1.3 Safety Instructions



Always observe the following instructions to prevent any physical and/or property damages.

- Operate the pump only under the specified pump.
- Any tension, contraction and strain on the piping system should never transfer to the pump.
- Electric wiring of the engine and auxiliary components should definitely comply with the local rules and be performed by the authorized personnel.
- Never perform any work on the pump before the pump set is stopped completely.



Always disconnect power connection with the engine before you perform any work on the pump and make sure that no connection is made accidentally.

- Any work on the pump should always be performed by at least two workers.
- Clothing of the personnel to work on the pump should always be suitable for the works they **will** perform and/or the personnel should use necessary safety equipment.
- Never perform any work on the pump when it is hot.
- Never touch the hot pump and pipes by naked hand. The user personnel should take necessary warning precautions (e.g. warning signs, barricades, etc.).
- Always be careful when working on the pumps delivering hazardous liquids (e.g. acid or hazardous fluids).
- When the pump and pipes connected to the pump are under pressure, do not perform any work on the pump definitely.
- Once the work on the pump is over, put in place all safety shields previously removed.
- Never operate the pump in reverse direction.
- Never insert your hands and fingers into any hole or openings of the pump.
- Do not trace on the pump and/or pipes connected to the pump.

1.3.1 CE signs and approvals

It is a legal requirement that machinery and equipment put into service within certain regions of the world shall conform with the applicable CE Marking Directives covering Machinery and, where applicable, Low Voltage Equipment, Electromagnetic Compatibility (EMC), Pressure Equipment Directive (PED) and Equipment for Potentially Explosive Atmospheres (ATEX).

Where applicable, the Directives and any additional Approvals, cover important safety aspects relating to machinery and equipment and the satisfactory provision of technical documents and safety instructions. Where applicable this document incorporates information relevant to these Directives and Approvals. To confirm the Approvals applying and if the product is CE marked, check the serial number plate markings and the Certification, see the last page of this document.

1.3.2 Explosive atmosphere



This section should be read carefully for the pumps operating at explosive atmospheres.



Only the products certificated for the explosive atmospheres should be used at the explosive atmospheres.

Detailed information about the operating conditions at the explosive atmospheres are found in Directive on Equipment for Potentially Explosive Atmospheres 94/9/EC (ATEX 95).

The pumps to be used at the explosive atmospheres should never be used at areas apart from the specified areas.

1.3.3 Labelling

Label on the pump is related with the pump only.

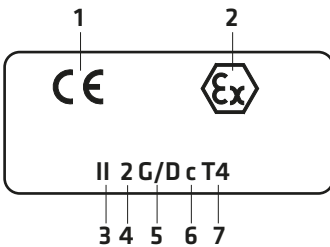

- 1- CE logo
- 2- Ex logo
- 3- Group
- 4- Category
- 5- Explosive Atmosphere [Gas(G) and/or Dust(D)]
- 6- Protection Type (Constructional Safety as per EN 13463-5)
- 7- Temperature Class

Example II 2 G/D c T4

II 2 G/D : Group II, Category 2 Gas (G) and/or Dust (D) ambient.

c : Constructional Safety (c)

T4 : Temperature Class (T4)

Motor: It is required to be documented and labelled by the engine manufacturer.

1.3.4 Temperature classes and limits

During the pumping applications, the highest temperature occurs in the areas of the electric motor bearing area, sealing area and volute casing. The volute casing temperature is almost same with that of the fluid delivered by the pump. If the pump casing is heated externally, the technical personnel should keep the temperatures under control according to the temperature classes.

Temperature classes given in the **Table 1** and the highest permissible temperature for the pump during operation are shown in the following table.

Temperature Limits

Temperature Class	Maximum Surface Temperature	Maximum Permissible Fluid Temperature
T3	200 °C	180 °C
T4	135 °C	110 °C

Table 1

1.3.5 Monitoring



Pump and/or pumpset should be operated according to duty point and the limit described in nameplate.

The technical personnel should operate the pump within these limits and the status monitoring system should be used for the pump set.

Use of the monitoring system is important especially for the following areas of the pump:

- Temperature values on the pump casing
- Temperature values in the sealing area

In the systems where buffer liquid is supplied or double mechanical seal is available the buffer liquid should be observed.

- Temperature values in the electrical motor bearing area

For proper operation of the bearings, it would also be useful to monitor vibration and temperature values in the roller bearing.

- The pump should be operated according to ordered duty point.

1.3.6 Constructional requirements

When explosive fluid is pumped, all parts under pressure should be made of ductile material.

Mechanical seals should never be operated dry. The sealing area should be filled with liquid completely as long as the pump operates. If you are not sure that the sealing area is filled with liquid, then the buffer liquid may be applied.

Pump and/or pump set should always be earthed.

1.3.7 Personnel qualification and training

All personnel involved in the operation, installation, inspection and maintenance of the unit must be qualified to carry out the work involved. If the personnel in question do not already possess the necessary knowledge and skill, appropriate training and instruction must be provided. If required the operator may commission the manufacturer / supplier to provide applicable training.

Always co-ordinate repair activity with operations and health and safety personnel, and follow all plant safety requirements and applicable safety and health laws and regulations.

1.4 Recycling

For products and parts which will not be used and scrapped, use the local or private waste collection services. If it is not possible, consult the nearest authorized service centre of STANDART POMPA.

ECO SNL PUMPS

2- GENERAL PUMP DESCRIPTION

2.1- Pump Description

• ECO SNL series pumps are horizontal, radially split volute casing, single stage, end suction centrifugal pumps with closed impeller.

2.2- Application Areas

ECO SNL series pumps are suitable for clean or slightly contaminated (max. 20 mg/dm³) liquids with low viscosities and temperatures up to 140 ° C . The main application areas, among others, are:

- Water supply, water treatment and irrigation systems,
- Heating, chilled and cooling water systems,
- Water systems for industrial uses,
- Industrial circulating systems,
- Fire fighting,
- Power plants.

2.3- Pump Designation

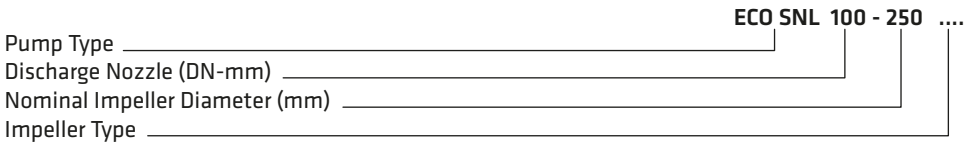

2.4- Product information according to European Commission's Regulation EU 547/2012

Relevant Pump Series

Water pump, end suction own bearing (ESOB) - ECO SNT

Water pump, end suction close coupled (ESCC) - ECO SNL

Water pump, end suction close coupled inline (ESCCi) - ECO SNL

Minimum efficiency index: $MEI \geq 0,4$

The benchmark for most efficient water pumps is $MEI \geq 0,7$

Year of production: Please see the pump label.

Manufacturer's name or trademark: **Standart Pompa ve Makina San. Tic. A.Ş.**

Place of production: Turkey

Product's type and size indicator: Please see the pump label and data sheets.

Pump performance curves, including efficiency characteristics: see documented characteristic curve

The efficiency of a pump with a trimmed impeller is usually lower than that of a pump with full impeller diameter. Trimming of the impeller will adapt the pump to a fixed duty point, leading to reduced energy consumption. The minimum efficiency index (MEI) is based on the full impeller diameter.

Operation of this water pump with variable duty points may be more efficient and economic when controlled, for example, by the use of a variable speed drive that matches the pump duty to the system.

Information relevant for disassembly, recycling or disposal at end of life: see installation/operating manual section 1.4

Information on benchmark efficiency graph is available at www.europump.org/efficiencycharts

2.5 Pump Name Plate

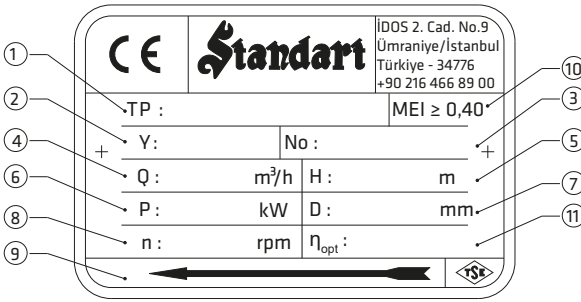

- 1- Pump Type and Size
- 2- Production Year
- 3- Serial No
- 4- Capacity
- 5- Head
- 6- Motor Power
- 7- Impeller Diameter
- 8- Speed
- 9- Direction of Rotation
- 10- Minimum efficiency index
- 11- Efficiency

2.6- Technical Information

Discharge Nozzle : DN 32 ... DN 200 mm
Operation Temperature : -10 °C up to 140°C
Casing Pressure (max) : 10 bar (16 bar)*
Permissible Liquids : **See Section 2.2**

The service life of this product as determined and announced by the Ministry is 10 years.

(*) Note: Contact our company for more detail.

3- UNPACKING, HANDLING and STORAGE

3.1- Unpacking

- Check whether the package has been damaged during transportation.
- Remove unpackaged pump and accessories (if any) carefully. Check whether they have been damaged during transportation.
- If any damage has occurred during transportation, notify SERVICE DEPARTMENT, **STANDART POMPA** and SHIPPING COMPANY about it immediately.
- Check whether all materials in the shipping list have been delivered. If there is any missing article, advise SERVICE DEPARTMENT, **STANDART POMPA**.
- Remove the liquid inside the pump, for preventing corrosion due to transportation.

3.2- Handling

3.2.1- General warnings



- Follow the rules at work to prevent occurrence of any accidents.
- Wear gloves, steel-tooled shoes and helmet during handling.
- You may use forklift, crane or hoisting ropes to lower wooden crates, packages, pallets or boxes depending on volume, weight and construction of them.

3.2.2- Lifting operation



- Determine the following points prior to lifting and handling the pump.

ATTENTION

- Total weight and centre of gravity,
- The largest outer dimensions, and
- Location of the lifting points.
- The load lifting capacity should comply with the weight of the pump or pump group.
- The pump or pump group should always be lifted and handled horizontally.
- Never stand under or near the load being lifted.
- Do not keep the load lifted longer than necessary.
- Accelerating and braking operations during the hoisting should not be performed in such a way that may be dangerous for the working personnel.

The pump or pump group should be hoisted as shown in the Figure 1a or Figure 1b in order to avoid from any deformation. (When the group is hoisted as a whole, never use the suspension hook of the electric motor.)

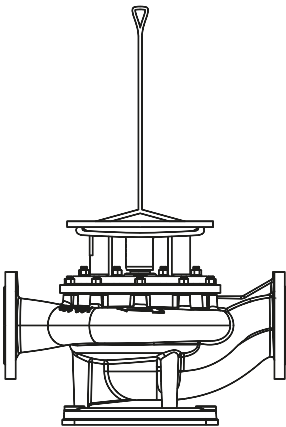

Figure 1a. Bare shaft pump

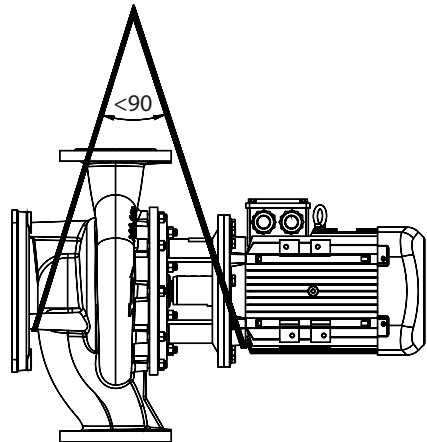

Figure 1b. Pump and motor on a common baseplate

3.3- Storage

- If the pump will not be installed in place immediately, it should be stored at a clean and dry place free of any frost hazard without excessive change in the ambient temperature.
- If the electric motor bearings are of grease-applied ones, extra grease should be applied to the bearings to prevent moisture ingress around the shaft.
- Necessary precautions should be taken to protect the pump against humidity, dust, dirt and foreign materials.
- The pump should be rotated manually by some turns occasionally (e.g. once in a week) to prevent pitting on the bearing surfaces and sticking of the pump.

4- INSTALLATION ON SITE

ATTENTION Installation on site should be performed as per EN 60204-1 standard.

Installation of the pump on site and levelling and adjustments of it should be performed only by qualified personnel. Improper installation may cause failure. Such situations are excluded from warranty.

4.1- Bare Shaft Pump

- If the pump is supplied without motor, proper motor should be selected before the pump is installed.
- Following points should be taken into consideration when selecting motor:
 - Maximum power drawn by the pump along the entire operating range,
 - Running speed of the pump,
 - Applicable power supply (frequency, voltage, etc.),
 - Motor type (TEFC, Exproof, etc.),
 - Motor connection form (pedestal, flanged, horizontal, vertical, etc.), and

4.2- Preparation for Installation

Prior to installation of the pump in place:

- Suction and delivery flanges should be cleaned thoroughly.

4.3- Installation Site

ATTENTION • The pump should be installed at a well-ventilated place free of freezing and explosion risk.

- There should be sufficient space around the pump being installed to allow easy access for maintenance of the pump as well as sufficient space above the pump to hoist it when required.
- Suction pipe of the pump should be short as far as possible.

4.4- Installation of the Piping System

4.4.1- General Warning

ATTENTION • Never use the pump as a point of support or bearer for the piping system.

- The piping system should be supported at points near to the pump. For this purpose, after completion of the installation of the piping system, loosen the bolts of the suction and delivery flanges and control whether the piping system applies any tension on the pump.
- **Rated diameter of the suction and delivery flanges of the pump are not indicator of the correct sizes of the suction and delivery pipes at all. The rated diameter of the pipes and accessories used should be equal to or larger than the inlet diameters of the pump at least. Never use pipes and accessories having smaller diameter than the inlet diameters of the pump.** Especially components such as bottom valve, strainer, dirt-retaining filter and check valves with larger free passage area should be preferred. In general, flow rates should not exceed 2m/s for the suction pipe and 3m/s for the delivery pipe. High speeds cause high pressure reduction and it, in turn, cause cavitation conditions on the suction pipe and loss arising from excessive friction on the delivery pipes.

- Pipe connections should be made with the flanges. Flange bolts should be made of proper material and in proper size. The flange bolts should be inserted between the flange bolts and centred in such way that it would not impair flow section.
- In case of excessive vibrations and systems operating with hot liquids, expansion parts should be used in order that any extra forces that may arise from thermal expansion are not transferred to the pump.
- Materials such as welding burrs, metal particles, sand and oakum arising from production of the piping system may remain in the pump and give damage to the pump. The suction and delivery flanges should be sealed blind washers in order to prevent such materials from entering into the pump during the assembly operations. After assembly, all pipe parts should be removed, cleaned, painted and reassembled. If dirt-retainer is used on the suction side of the pump, the dirt-retainer should be cleaned after working for several days.

4.4.2- Suction pipe

- The suction pipe should be definitely watertight and should not be arranged in a way to cause formation of air pockets. In other words, if it is supplied from a reservoir higher than it (system with elevated suction/supply), the suction pump should be slightly declined towards the pump; and if the pump is supplied from a reservoir lower than it (system with suction depth), then the suction pipe should be gradually inclined slightly towards the pump. **Figure 2a and 2b**
- In order to keep the loss from friction, sharp elbows should not be used; and abrupt change of direction and section should be avoided and suction pipe should be made short as far as possible. If it is required to make change of section on a horizontal suction pipe, an eccentric conical spacer with its flat side on the top should be used.

ATTENTION • If the pump is supplied from a reservoir higher than it, an insulation valve should be used to keep the axis on the suction pipe horizontally. This valve should always be open when the pump operates and it should never be used as flow rate adjusting valve (Caution: Throttle of the valve may cause the pump to operate with cavitation).

4.4.3- Delivery pipe

- A flow control valve should be connected on the delivery pipe, near the pump as far as possible in order to adjust the flow rate and delivery head.
- If the delivery head of the pump is more than 10 m or the delivery line is quite long, a check valve should be connected between the pump and flow rate adjusting valve on the delivery pipe in order to protect the pump against water hammers when stopping the pump or prevent backflow.

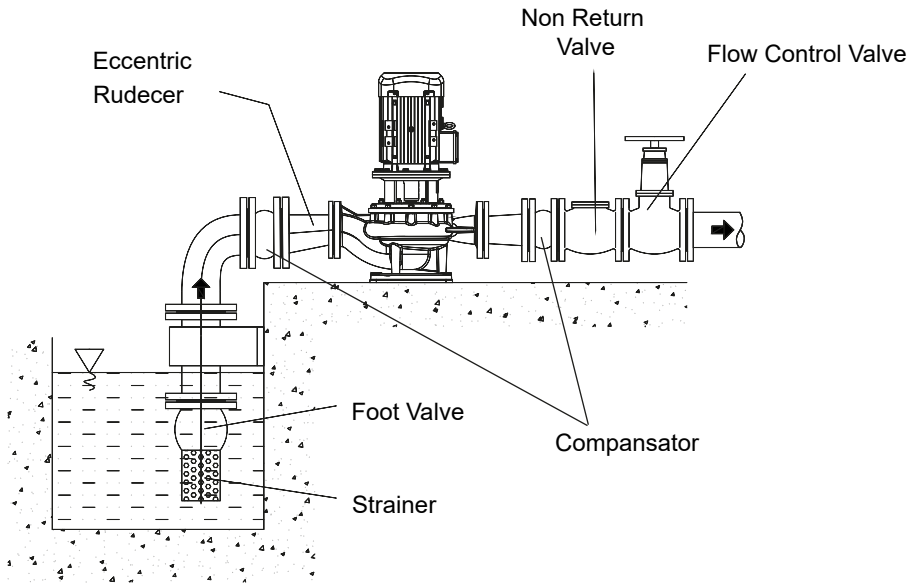

Figure 2a. Suction Lift

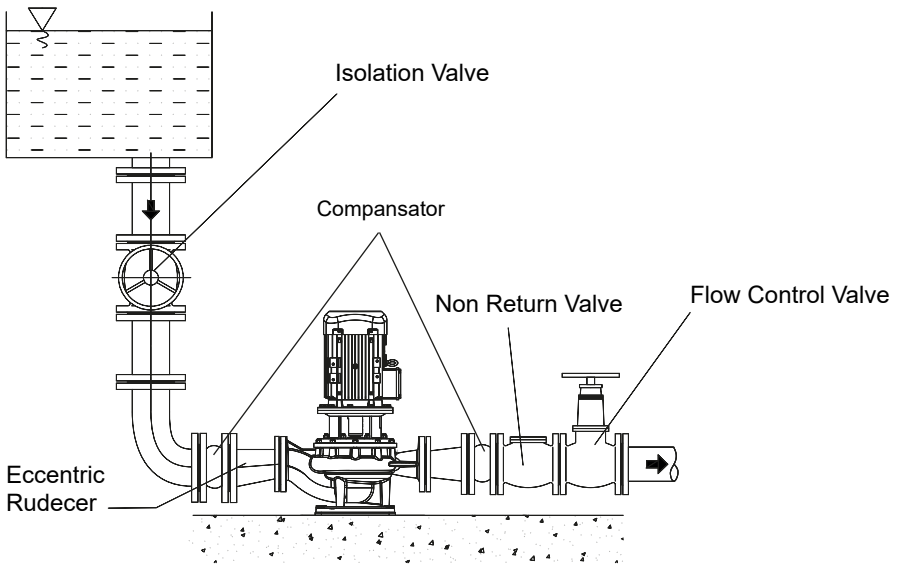

Figure 2a. Suction Flooded

4.4.4- Auxiliary pipe connections and accessories

- Depending on the application auxiliary pipe connections (for cooling, sealing and flushing of seal, drainage etc. necessary for the pumping system) and/or accessories to check operating conditions (pressure gauges, temperature gauges etc.) may be made up and lail.
- Pressure and vacuum gauges must be properly anchored and connected at the measuring points located on the pump flanges by means of or on the pipes close to the flanges approximately 8 mm diameter tubing with pig tail configuration to lessen pressure fluctuation. For safety purposes isolating and vent valves should be fitted before the gauges (**Figure 3 and 4**).
- Cooling, sealing and flushing of seal piping must be connected only to the designated connections located on the pump (**Figure 5,6**).

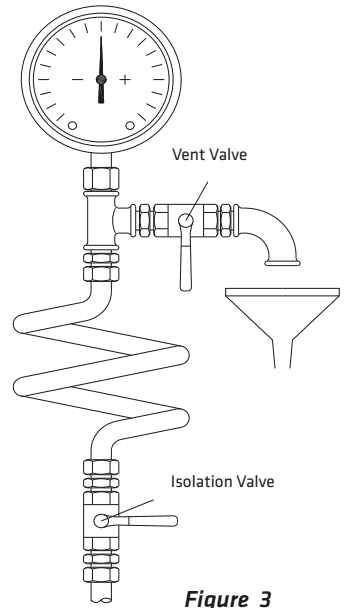

Figure 3

- d1 : Pressure gauge (discharge)
- d2 : Pressure gauge (suction)

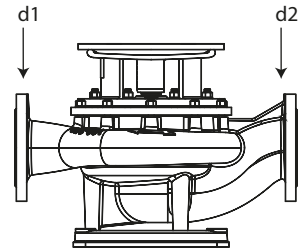

Figure 4

- F1: Seal flushing liquid inlet from external source
- Q1: Mechanical seal quench liquid inlet from external source.
- Q2: Mechanical seal quench liquid outlet.

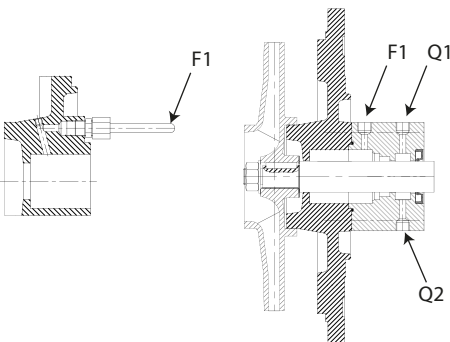

Figure 5

Figure 6

4.5- Minimum Flow



If there is possibility of the pump operating with its delivery valve is closed completely (that is, at zero flow rate) or almost closed (that is, at very little rate), a by-pass valve should be used on the outlet flange of the pump or on the delivery pipe just after the pump, but in advance of the control valve should be used. If such a valve is not used and the pump operates for a long time, almost all power given by the engine converts to thermal energy and transfers to the delivered liquid. This situation may cause overheating and, consequently, cause significant failures.

4.6- Electrical Connections



- The electrical motors have to be built in accordance with EN 60034-1.
- Enclosures of electrical motors and control systems on the pump unit shall as a minimum have protection in accordance with EN 60529 IP22. But in determining the degree of protection of enclosures of electrical motors and control systems on the pump unit the operating and environmental conditions must be taken into consideration.

- Electrical connection should be done by a qualified electrician. Current national regulation and motor manufacturer's instructions must be observed.
- Take all safety precautions listed in "Safety instructions". Disconnect all power supplies prior to doing any work.
- The supply cable must be laid in such a way that it never touches the pipework, pump and motor casing.
- Check voltage, phase and frequency on motor nameplate with the mains.
- The electric motor must be protected against overloading by means of circuit breakers and/or fuses. Circuit breakers and fuses must be selected in accordance with full load amperage of the motor appearing on the motor rating plate.
- It is recommended to use PTC (passive thermal control) on motor, but this is optional depending on customer requirement. In case of using PTC, these should be connected via corresponding terminals in the terminal box and the PTC should be connected to the thermal trip mechanism.
- Prior to connection the electrical wiring rotate the pump shaft by hand to make sure rotor rotates easily.
- Connect the electrical wiring in accordance with local electrical codes and make sure to ground the motor.
- The connection diagram can be found in the terminal box of the motor or in the instruction manual.
- The mains connection on the terminal box depends on the nominal power of the motor, the power supply and the type of connection. The necessary connection of the bridges in the terminal box is shown in the following (*Table 2 ve Figure 7a, 7b, 7c*).

Type of switch	Motor Power $P_N \leq 4 \text{ kW}$	Motor Power $P_N > 4 \text{ kW}$
	Power Supply 3 ~ 400 V	Power Supply 3 ~ 400 V
direct	Y - connection (11b)	Δ - connection (11a)
Y / Δ - start	Impossible	Remove connection bridges (11c)

Table 2

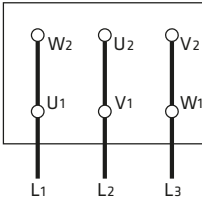

Figure 7a. Δ - connection

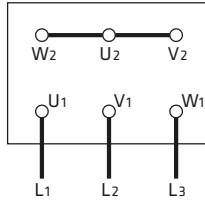

Figure 7b. Y - connection

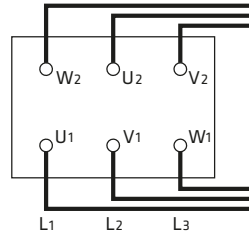

Figure 7c. Y / Δ - connection

DİKKAT

In the case of three-phase induction motors with Y - Δ connection it must be ensured that the change-over points between star and delta follow on from one another very quickly. Longer change-over times may result in pump damage (Table 3).

Motor Power	Y - set time
$\leq 30 \text{ kW}$	< 3 second
> 30 kW	> 5 second

Table 3

4.7- Final Controls

- The pump rotor should be rotated several times manually to make sure it rotates easily.
- All security guards should be put in place.
- And the pump group should be operated and you should allow until the operating and heating conditions are reached.



- The pump should never be operated before the safety guards are put in place. This is a security and safety rule at workplace which should be definitely observed.

5- START UP / SHUT DOWN

5.1- Preparation

5.1.1- Venting and priming

- Make sure that the pump and suction pipes are completely filled up with water. There is no problem for the pumps which have positive suction head. If there is a valve on suction line, it must be opened to enable the water replaces air in the pump, until it is completely full with water.
- If there is a foot valve on the suction line, the air should be emptied out.
- If the system has a vacuum pump, water is brought up in the rising pipe and filled up the pump through this vacuum pump. When water is risen up to the highest point then the pump is started up.

ATTENTION Make sure the pump never runs dry.

5.1.2- Checking the direction of rotation

- ECO SNL type pumps rotate in clockwise when it is looked from coupling to the pump. This direction is already indicated on the pump nameplate by an arrow. Check this by switching the pump on, then off again immediately. Fit the coupling guard back in place if you took it out.

5.2- Start Up The Pump

- Check if the shut off valve in the suction line is open and the shut off valve in discharge line is closed.
- Switch on the circuit breaker and run the motor.
- Wait until the motor reaches the full speed (on star-delta running motors wait until it switches on delta).
- Open the discharge valve slowly while watching the ampermeter on the control panel (if the discharge line is empty do not turn on the valve fully open on first start up. Turn it on slowly to maintain the value on the ampermeter is under the rated current value of the motor).
- When the valve is if fully open, check the pressure on the manometer and see it is the same with the duty point pressure. If the pressure on the pressure gauge is lower than duty point pressure brings them to the duty point value by slightly closing the valve. If it is higher value, check your installation, especially geometric height again.

ATTENTION The pump should be shut down at once and the trouble should be corrected if the pump is running at its rated speed and found any of the following faults:

- Pump doesn't deliver any water,
- Pump doesn't deliver enough water,
- Flow is going down,
- Discharge pressure is not enough,
- Driver overloaded,
- Vibration on pump,
- High noise level,

5.3- Shut Down The Pump

- Slowly close the shut-off valve in the discharge line.
- You may shut down pump without closing the shut-off valve if there is a device for water hammer protection on the discharge line or the water hammer is not a considerable level.
- Switch off the drive. Ensure the pump set runs down smoothly and quietly to a standstill.
- Shut off external sealing liquid supply, if supplied to relieve stuffing box pressure.
- If the set is to remain out of services for a long time close the shut-off valve in the suction pipe. Close off the auxiliary connections. In the event of frost and/or prolonged standstill, drain the pump or otherwise protect against freezing.

5.4- Checks to be Made While The Pump is Running



- **The pump must never run dry.**
- **Never run the pump for along period against a closed discharge valve (at zero flow)**

- The valves in the auxiliary lines must remain open while the pump is running.
- If the pump has a mechanical seal, experience only minor leakage or no visible leakage during operation. It is maintenance free. If there is considerable leakage from the seal, that means the seal surfaces are worn-out and it needs to be replaced. The operation life of the mechanical seal highly depends on the purity of the liquid.
- Occasionally check the motor current. Stop motor if the amperage is higher than usual; there may be jamming or friction in the pump. Make the necessary mechanical and electrical checks.
- Stand-By pumps should be run for a short time at least once a week to ensure they are in constant readiness for operation. Check the integrity of auxiliary connections.

6- DISASSEMBLY AND REASSEMBLY



Before working on the pump, always disconnect the electrical connections and ensure that you take all the necessary actions to prevent undesired operation.



Strictly follow the instructions given in “Safety Instructions” section.

6.1- Disassembling the Pump

- Shut off the isolation valves on the suction and delivery line. Drain the water inside the pump.
- Disconnect the pump from the piping system by removing the suction and delivery flanges of the pump and auxiliary pipe connections.
- Dismantle the safety guards. (550)
- Dismantle stud, washer and nut (301) from the volute casing (001). So the volute casing (001) might be removed easily.
- Dismantle the impeller nut and washer (065).

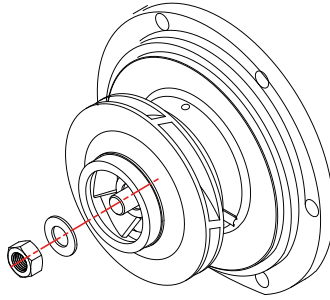

Figure 8. Disassembly of impeller

ATTENTION The sharp areas on the impeller edges can injure. Use protective gloves.

- Remove the impeller (050) with lever or screwdriver and etc.
- Remove the impeller key (210). Use rust remover solvent, if necessary.
- Remove the O-ring (420).

ATTENTION The O-rings used after dismantling the pump must always be replaced.

- Take the mechanical seal spacer sleeve (049) or shaft sleeve (070).
- Remove the mechanical seal (405).
- Remove the mechanical seal cover(043).
- Refer to **(Section 6.4.1)** for mechanical seal.

ATTENTION Be careful when removing the mechanical seal. Any potential impact on the stationary element of the mechanical seal may cause the breakdown of the mechanical seal.

- Remove the shaft (060) by untightening the set screws (380)
- If rigid coupling is used, remove the shaft by untightening screws (320) from rigid coupling (093)
- Remove the allen screw and washer (340). It is easy remove rigid coupling (093) from electric motor (600).
- Remove the motor pedestal (005) from electric motor.

6.2- Tightening Torques

ATTENTION The following tightening torques must be taken into consideration when tightening the bolts and nuts during installation.

Thread Diameter	Tightening Torques (Nm)
M6	7
M8	20
M10	40
M12	65
M14	100

Table 4

Thread Diameter	Tightening Torques (Nm)
M16	130
M18	140
M20	140
M22	140
M24	200

Table 4 (continue)

6.3- Assembling the Pump

6.3.1- Getting Prepared for Mounting

• It must be ensured that the parts to be used are clean before starting mounting. Clean the oil, dirt on the parts with a solvent.

ATTENTION Be careful with processed surfaces. The defects on the processed surfaces may cause permanent damages.

- The impeller and the body must be inspected for wear, fraction and breakdown.
- Replacement is necessary if the radial clearances between the impeller and the volute casing 1 mm.
- It must be ensured that the surfaces of the O-ring and/or bolts are clean.

6.3.2- Mounting

The mounting procedure is the reverse of the demounting procedure. Exploded view or cross sectional view can be referenced during mounting.

- Put the shaft (060) on the electric motor (600). Don't tighten the set screw (380) completely.
- If rigid coupling is used, put the rigid coupling (093) on the electric motor (600) shaft.
- In sequence, put allen screw and washer (340), shaft (060) with screws (320).
- Put the thrower (088) on the shaft.
- Assemble the motor pedestal (005) on the electric motor (600).
- Put the mechanical seal cover (043) on the motor pedestal (005).

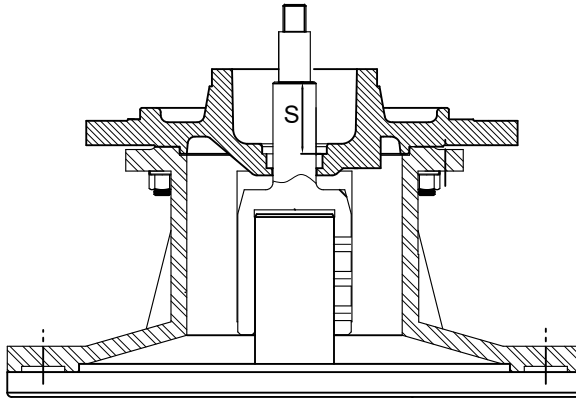

Figure 9. Mounting the pump shaft on the electric motor shaft

- According to pump group, arrange S value (see table 5) tighten the set screw (380) completely on the shaft.
- First put the stationary part of mechanical seal (405) and after that put the rotary part.
- Put the mechanical seal spacer sleeve (049) on the shaft (060).
- Attach the impeller key (210).
- Insert the impeller (050) and tighten the impeller nut (065).

- Mount the O-ring (420) of the body.

ATTENTION

It must be ensured that the O-rings are seated properly and they are not crushed or compressed during mounting.

- Connect the volute casing (001).
- Connect the suction - delivery and auxiliary pipes.
- Start-up the pump group as described in Section 5.

6.4- Shaft Seal

6.4.1- Pump with mechanical seal

- When operating properly the mechanical seal has no visible leakage. Usually mechanical seals do not require maintenance until leakage is visible but its tightness is to be checked regularly.
- Follow the instructions of mechanical seal manufacturers for the pumps having mechanical seal and NEVER RUN IT DRY!
- The mechanical seal diameter and soft packing cross section of ECO SNL type pumps are given below **Table 5**.

Pump Dimension Group	Mechanical Seal Diameter \varnothing	S (mm)
A	30	50
B	40	55
C	50	62

Table 5

Note: Different types of mechanical seals with different diameters can be applied for various applications. Please ask STANDART POMPA for more information.

Mechanical Seal Application

MG1 G6
MG1 G60

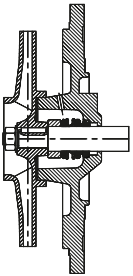

Figure 10a

M3N
M37G

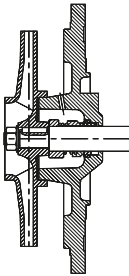

Figure 10b

M7N

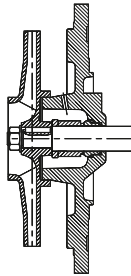

Figure 10c

H12N
H75N

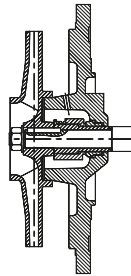

Figure 10d

RMG 12 G606

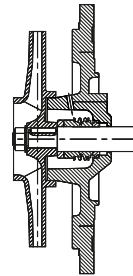

Figure 10e

CARTEX SN

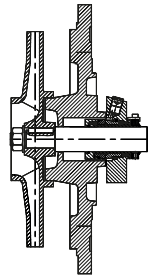

Figure 10f

7- SPARE PART

- STANDART POMPA guarantees to supply the spare parts for ECO SNL type pumps for 10 years. You can provide any spare parts easily.
- Lets us know the following details on the name-plate, when you order spare parts.

Pump Type and Size : (ECO SNL 65-200)
 Motor Power and Speed : (30 kW – 2900 d/min)
 Prod. Year and Serial Number : (..... –)
 Capacity and Head : (120 m³/h – 57 m)

- If you prefer to have spare parts in your stock, we recommed you to have the following quantities for two years operation depending on the number of same of pumps (**Table 6**).

Part Number	Part Name	Number of Pumps in the Systems						
		2	3	4	5	6-7	8-9	10+
020*-021*	Wear Rings (set)	1	2	2	3	4	5	50%
050	Impeller (piece)	1	1	2	2	3	4	30%
060	Shaft (incl. keys) (piece)	1	1	2	2	2	3	30%
070*	Shaft Sleeve (piece)	1	1	2	2	2	3	30%
405*	Mechanical Seal (piece)	1	1	1	2	2	3	30%
420	O-Ring (piece)	4	6	8	8	10	12	150%

(*) optional

Table 6

8- FAULTS, CAUSES and REMEDIES

In this section you will find operating faults which may arise, and their causes (**Table 7**), and suggested remedies (**Table 8**).

FAULTS	POSSIBLE CAUSES
Pump does not deliver any water after start-up	1-5-7-10-11-13
Flow is going down or no flow at all	1-2-3-4-6-7-8-14
Driver overloaded	9-12-17-22-23
Bearings overheating	18
Vibration on pump	6-9-15-16-19-20
Noise level is high	4-6-21

Table 7

	POSSIBLE CAUSES	REMEDY METHODS
1	May be air in the pump and/or suction line	Fill the pump and suction pipe with liquid completely and repeat the start-up operation.
2	Air intake from the seal, suction pipe or connections. Pump intakes liquid mixed with air.	Check all connections on the suction pipe. Check the seal and supply pressurized liquid to the seal, if required. Check immersion depth of the suction pipe or bottom valve and increase the immersion depth, if required.
3	Air pocket in the suction pipe	Check inclination of the suction line and whether there are parts susceptible to formation of air pockets and if there are make necessary corrections.
4	Air in the liquid	Eddies occur due to insufficient immersion depth of the suction pipe causing to air intake. Check liquid level in the suction reservoir or increase immersion depth of the suction pipe / bottom valve.
5	Suction depth too much	If there is no obstacle leading to clogging in the suction, check friction loss on the suction line and use suction pipe with large diameter, if required. If the static suction depth is too much, you should either increase the liquid level in the suction reservoir or move the pump to a lower level.
6	Pump operates with cavitation	NPSH of the plant is very low. Check the liquid level in the suction reservoir. Check whether there is excessive friction loss on the suction line. Check whether the insulation valve on the suction line is completely open. If required, reduce the pump to a lower level and increase load on the pump suction.
7	Delivery head of the pump is insufficient	Actual delivery head of the plant is higher than the specified one. Check the total static height and friction loss of the suction pipe. Use of pipe with larger diameter may act as remedy. Check whether the valves are completely open.
8	Increased delivery head	Check whether the valves are completely open. Check whether there is any obstacle causing clogging in the suction pipe.
9	Pump operates at a lower delivery head.	Actual delivery head of the plant is less than the specified one. Machine the impeller diameter in accordance with the manufacturer's recommendation.
10	Pump returns reverse.	Check whether the engine's direction of rotation complies with the direction of rotation indicated on the pump casing or name plate.

Table 8

	POSSIBLE CAUSES	REMEDY METHODS
11	Low speed	Check mains voltage and frequency or whether there is phase faults in the engine
12	Speed too high	Reduce the pump speed, if possible or machine the impeller diameter according to the manufacturer's recommendation.
13	Impeller, check valve or strainer clogged	Clean the impeller, check valve or strainer.
14	Impeller or strainer partly clogged	Clean the impeller or strainer.
15	Impeller partly clogged.	Clean the impeller.
16	Worn or broken impeller	Replace the impeller
17	Mechanical friction on the pump	Check whether there is obstacle or bending on the pump rotor.
18	Flow rate is less than the required minimum flow rate	Increase the flow rate. Use by-pass valve or line, If required.
19	Bent shaft	Check the shaft and replace it, if required.
20	Instable rotating parts	Check stability of the rotating parts.
21	Pump operates beyond the area of operation	Check the values of the area of operation
22	Density or viscosity of the delivered liquid is more than the specified value.	Use engine of higher power.
23	Enging fault	Check the engine. Engine ventilation is not proper due to its position.

Table 8 (continue)

9- EXPECTED NOISE VALUES

Motor Power - P_N (kW)	Sound Pressure level (dBA) * (Pump and Motor)	
	1450 rpm	2900 rpm
<0.55	60	64
0.75	60	66
1.1	62	66
1.5	63	68
2.2	64	69
3	65	70
4	66	71
5.5	67	73
7.5	69	74
11	70	76
15	72	77

Table 9

Motor Power - P_N (kW)	Sound Pressure level (dBA) * (Pump and Motor)	
	1450 rpm	2900 rpm
18.5	73	78
22	74	79
30	75	81
37	75	82
45	76	82
55	77	84
75	78	85
90	79	85
110	80	86
132	80	86
160	80	86

Table 9 (continue)

(*)The values measured at a distance of 1 m from the pump in the free area on the sound reflecting surface without sound curtain

(*)These values apply if the pump is operated in normal ordered operating values without cavitation.

(*)If the pump is operated at 60 Hz; increase the values in the table by 1 dB for 1800 rpm and by 2 dB for 3600 rpm.

10- PUMP DIMENSION GROUPS

Tip ECO SNL	Dimension Group	Design Form	Mechanical Seal Diameter \varnothing
40-125	A	F1	$\varnothing 30$
50-125			
65-125			
80-125			
40-160			
50-160			
65-160			
80-160			
100-160			
40-200		F2	
50-200			
65-200			
80-200			
50-250			
65-250			
100-200	B	F1	$\varnothing 40$
125-200			
80-250			
100-250			
125-250			
150-250		F2	
65-315			
80-315			
100-315			
125-315			
150-315	C	F1	$\varnothing 50$
200-315			
100-400			
125-400			
150-400			
200-400			
		F2	

Table 10

11- SECTIONAL DRAWINGS

Form: F1 (Slide - fit shaft application)

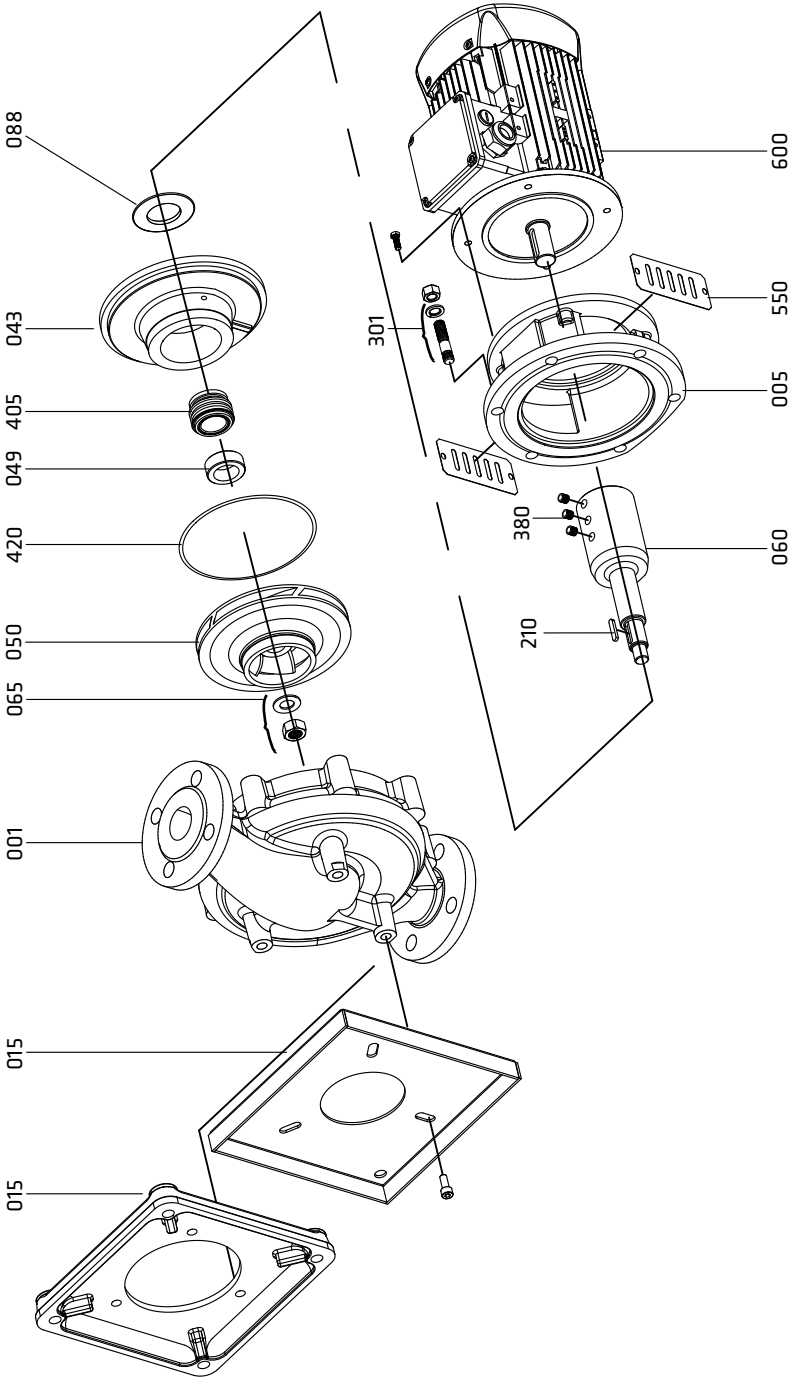

Form: F2 (Slide - fit shaft application)

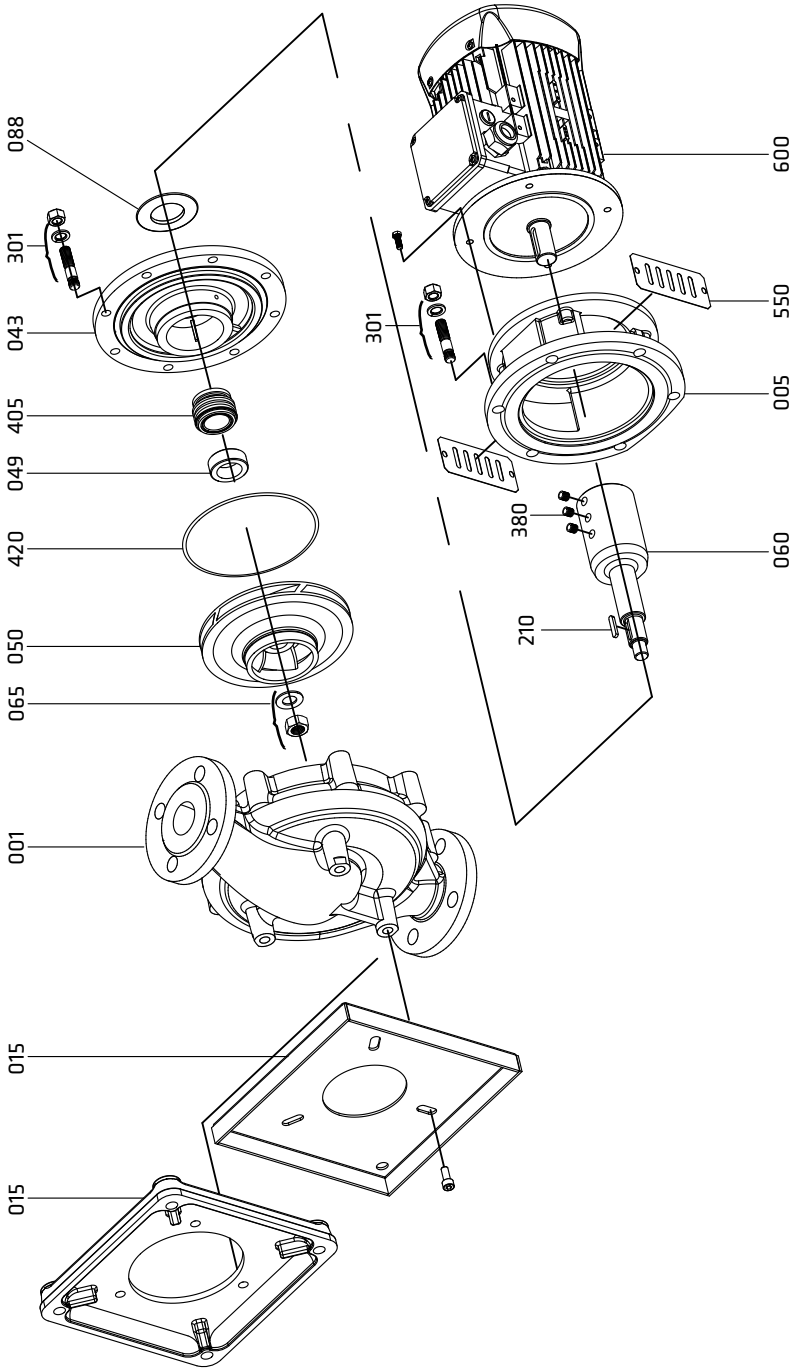

Rigid Coupling Application
For motor shaft diameters of $\varnothing 60$ mm or bigger.

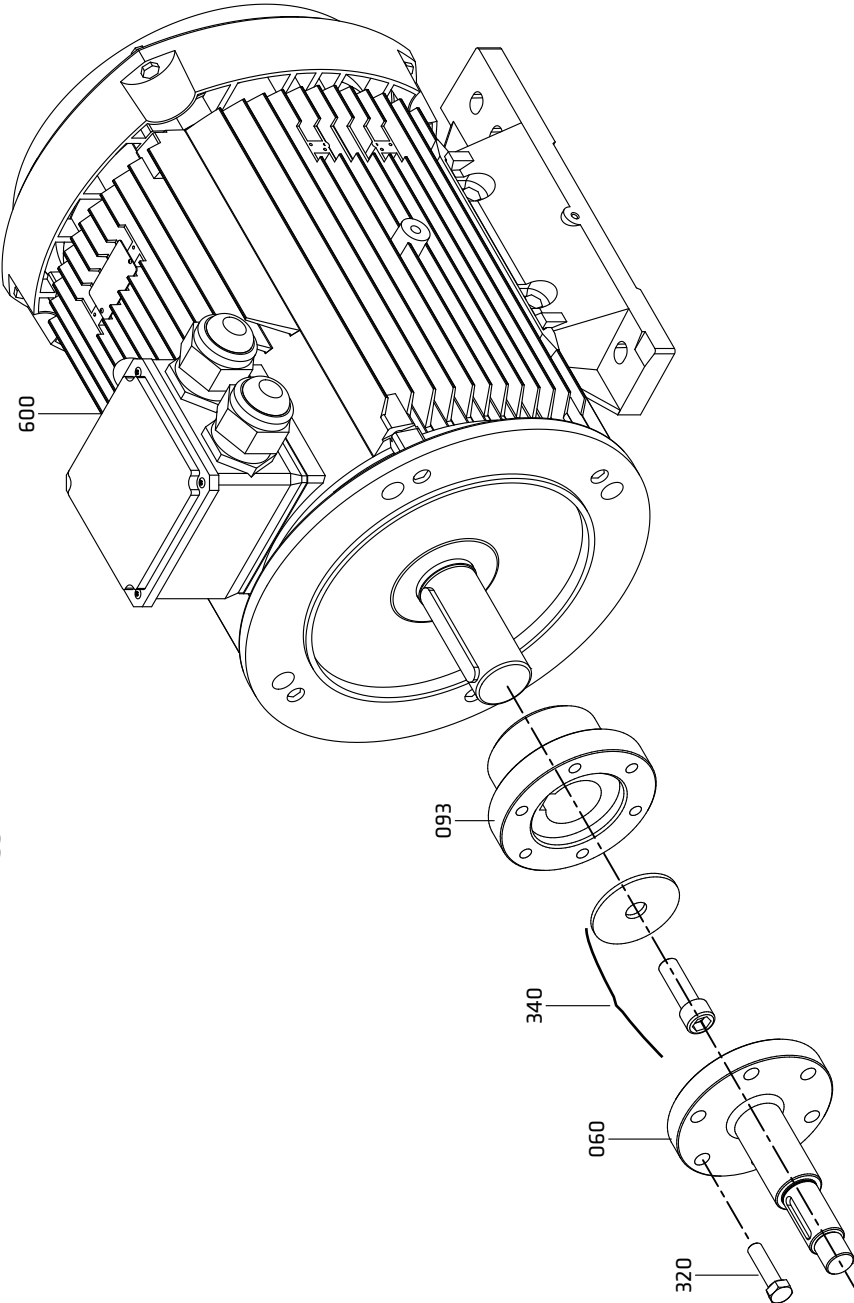

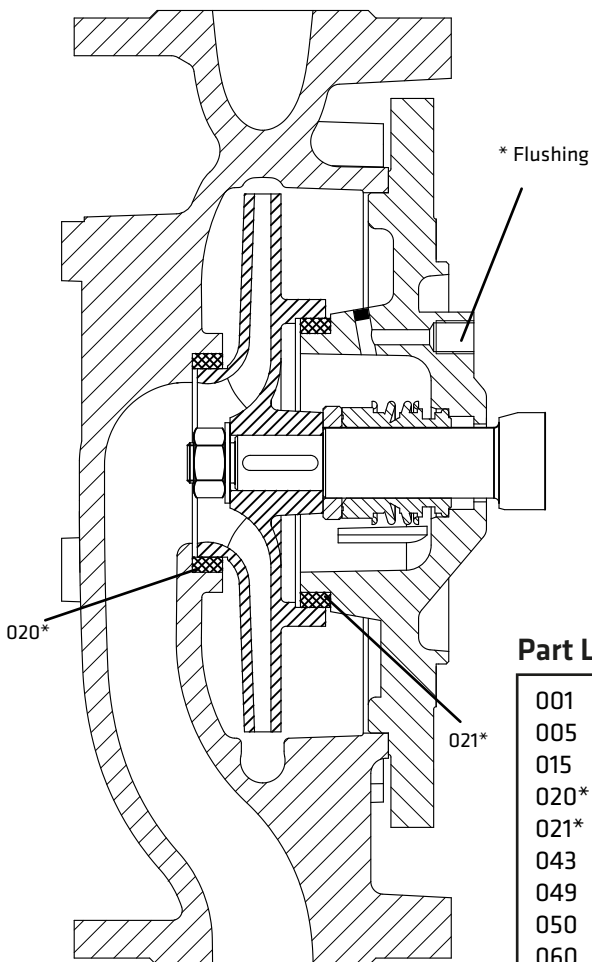

Part List

001	Volute Casing
005	Motor Pedestal
015	Bottom Plate
020*	Wear Ring (casing)
021*	Wear Ring (seal cover)
043	Mechanical Seal Cover
049	Mechanical Seal Spacer Sleeve
050	Impeller
060	Shaft
065	Impeller Nut and Washer
088	Thrower
093	Rigid Coupling
210	Impeller Key
301	Stud, Washer and Nut
320	Screw
340	Allen Screw and Washer
380	Set Screw
405	Mechanical Seal
420	O-ring
550	Guard
600	Electric Motor

(*) Optional

EC DECLARATION OF CONFORMITY

MANUFACTURER NAME:

Standart Pompa ve Makina San. Tic. A.Ş.

Dudullu Organize San. Bölgesi 2. Cad. No:9 34776 Ümraniye / İSTANBUL

t: +90 216 466 89 00 f: +90 216 415 88 60 - www.standartpompa.com / info@standartpompa.com.tr

The undersigned declares that the described products meet the essential requirements of the below mentioned standards as based on Machinery Directive 2006 / 42 / EC .

The item of equipment identified below has been subject to internal manufacturing checks with monitoring of the final assesment by our company.This declaration refers to the machinery in delivery status.Any modifications of the machinery by the end user shall invalidate this declaration.

EQUIPMENT DESCRIPTION : Centrifugal Pumps MODEL/ TYPE : ECO SNL

DIRECTIVES:

Machinery Directive 2006 / 42 / EC - Low Voltage Directive 2014 / 35 / EC

Regulations Applied acc. to HARMONIZE STANDARDS:

EN ISO 809:1998+A1:2009, EN ISO 12100:2010, EN 60204-1:2006/AC:2010

The Person Authorised To Compile The Technical File

Fatih ÇOBAN

05.09.2019

İSTANBUL

Signed On Behalf Of The Manufacturer

Şeref T. ÇELEBİ

Genel Müdür Yrd.

**Standart**
Pompa ve Makina
Saraylı Ticaret Anonim Şirketi

MANUFACTURER DECLARATION OF CONFORMITY

Products: Pumps of type ECO SNL (bareshaft)

Standart Pompa ve Makina San. Tic. A.Ş.

Dudullu Organize San. Bölgesi 2. Cad. No:9 34776 Ümraniye / İSTANBUL

t: +90 216 466 89 00 f: +90 216 415 88 60 - www.standartpompa.com / info@standartpompa.com.tr

The manufacturer here with declares that the described products meet the essential requirements of Machinery Directive **2006 / 42 / EC**.

Before the pump is put into operation, the machinery unit in which the pump is functioning to be declared in conformity to relevant regulations.

Harmonised standards applied are;

- EN 809
- EN ISO 12100:2010

**Standart**
Pompa ve Makina
Saraylı Ticaret Anonim Şirketi

Şeref T. ÇELEBİ
General Vice Manager

Proteggere la vita
Inochi o mamoru
Yaşamı Koru
Protéger la vie
Proteger la vida
Save Life!
Skydda Livet Schützen Sie Leben



All rights reserved. Can not be copied or reproduced for any purpose without permission.
Subject in the manual can be changed without any prior notice.

Factory - Company
Service

STANDART POMPA VE MAKİNA SANAYİ TİC. A.Ş.

Dudullu Organize Sanayi Bölgesi, 2. Cadde
No: 9 34775 Ümraniye İstanbul / Türkiye
T: +90 216 466 89 00 F: +90 216 499 05 59

www.standartpompa.com / info@standartpompa.com.tr